

**SONY®**

Network Color Camera

# SNC-VL10N/VL10P



The SNC-VL10N/VL10P is an IP Network camera for the Broadband Network era. Incorporating a built-in web server and a 1/3 type CCD with Super HAD™ technology, the SNC-VL10N/VL10P is ideal for remote monitoring applications. With its networking capability, this camera provides significant advantages over traditional camera systems, including easy and flexible installation with a user-friendly web browser GUI (Graphical User Interface).

The SNC-VL10N/VL10P is compatible with a variety of networks such as Ethernet, xDSL, cable modem and PSTN. Images captured by the SNC-VL10N/VL10P are encoded into Wavelet-format signals with high compression rates (ideal for network transmission) and then are transmitted as high-quality digital images over a network. Users can monitor live images from client PCs at any location and at any time by using popular web browsers such as Microsoft® Internet Explorer and Netscape® Navigator.

The SNC-VL10N/VL10P also enables alarm-data transmission. Its functions include activity detection, one sensor input and two sensor outputs. In addition, other devices can be controlled using a PC and the optional RS-485/RS-232C data transparency interface.

The versatile and flexible SNC-VL10N/VL10P camera is the ideal choice for surveillance applications such as security control, remote monitoring applications (production lines and web attractions) and general IT applications (weather, tourism and web casting).



## F E A T U R E S

### Remote monitoring over network

The SNC-VL10N/VL10P is equipped with a built-in web server to enable users to easily monitor live images from an online client PC. The SNC-VL10N/VL10P is not limited to a simple one-to-one system but can also function as a large-scale monitoring system with up to 100 users simultaneously monitoring operations.

### Monitoring with a standard web browser

The SNC-VL10N/VL10P transmits Wavelet-format compression images continuously over a network. These images can be viewed on the following browsers and operating systems without the need for special viewer software:

#### Supporting operation system (OS) and web browser

OS	Web browser
Microsoft Windows® 98/Me/NT/2000	Internet Explorer version 5.0, 5.5 or 6.0 Netscape Navigator version 4.7 or 6.0*1
Macintosh®/UNIX/Linux®	Java Applet-enabled browser*2

\*1 Only the Java Applet-enabled version 6.0 browser supports the SNC-VL10N/VL10P.

\*2 The SNC-VL10N/VL10P may not perform to specifications when using this browser.

### Various network-connection capabilities (RJ45 and USB support)

Equipped with a RJ-45 port and USB port as an interface between the camera and network, the SNC-VL10N/VL10P supports the following networks:

- RJ-45: Ethernet (fixed IP, DHCP), cable modem (DHCP), xDSL (DHCP), xDSL (PPPoE)
- USB: PSTN (PPP)

Besides the TCP/IP protocol, the SNC-VL10N/VL10P also supports the PPP protocol and incorporates a USB port\* for use with a telephone line. This allows images to be transmitted via an analog modem wherever a telephone line is available.

\* USB modem is required.

### Easy installation and set-up

The SNC-VL10N/VL10P supports standard network protocols such as TCP/IP, HTTP, ARP, RARP, ICMP, DHCP, PPP, PPPoE, FTP, SMTP, SNMP, and also has an 10 Base-T Ethernet interface. What's more, no special software or tools are needed to integrate the camera over a network. Installation is easy; all you have to do is assign an IP address to each camera and connect the Ethernet cable to an existing network. Set-up can also be easily achieved with the supplied set-up program.

## Wavelet format

The SNC-VL10N/VL10P encodes images to the Wavelet format that produces high-quality images without block noise or mosquito noise, despite its high-compression rate. Thanks to the high scalability of Wavelet compression images, the resolution (number of pixels) or picture quality can be changed to enhance a part of an image.

### Comparison between JPEG format and Wavelet format:



## Selectable image size

One of the features of the Wavelet format is the ability for users to change the picture size and resolution on each of their PCs according to network bandwidth. Five picture resolutions are selectable: 720 x 486, 720 x 243, 360 x 243, 180 x 121 and 90 x 60 for the SNC-VL10N, or 720 x 576, 720 x 288, 360 x 288, 188 x 144 and 90 x 72 for the SNC-VL10P.

The SNC-VL10N/VL10P supports Monochrome mode for narrowband users. Therefore, while one user can see a color image with a 720 x 486 resolution (SNC-VL10N), another user can see the same image with a 360 x 243 resolution (SNC-VL10N) in monochrome.

## Focus-area setting

Users with a high access authority can set a free-sized focus area within one image. This function is useful when users want to see an important part of an image in detail without losing the entire image. The image around the focus area can be set in five levels according to the degree of transparency of the masking (including opaque gray). By masking the non-focus area, its image data size gets smaller and creates a faster image transmission.



Normal



Focus area setting

## Alarm function

The SNC-VL10N/VL10P is equipped with a port for one sensor input and two sensor outputs that supports versatile alarm functions.

Crucial functions for security/surveillance applications are activated when an alarm input is triggered:

### ■ Alarm indicator

Alarm indicator appears at the bottom-right corner of the PC screen for easy identification purposes.

### ■ E-mail distribution by SMTP (Simple Mail Transfer Protocol)

The SNC-VL10N/VL10P sends an e-mail message to pre-registered e-mail addresses with an attached Wavelet image (360 x 243 resolution for the SNC-VL10N, or 360 x 288 picture resolution for the SNC-VL10P). Users can define up to two e-mail addresses.

### ■ Transfer to server by FTP (File Transfer Protocol)

The image (360 x 243 picture resolution for the SNC-VL10N or 360 x 288 picture resolution for the SNC-VL10P) shot at the time of an alarm event is saved and transferred to a pre-registered server. Users can define up to two servers of their choice.

### Pre/post-alarm image storage

Thanks to 16 MB of embedded RAM, the SNC-VL10N/VL10P can store a maximum of 50 frames of pre-alarm and post-alarm images at an alarm input. Users can define up to 25 frames of pre-alarm images and up to 25 frames of post-alarm images. These images can then be transferred by SMTP to pre-registered IP addresses as an E-mail attachment or by FTP to pre-registered servers. This function enables users to see what happened before and after an alarm occurred.

### Activity detection

When the internal video sensor detects movement in the live video signal, the SNC-VL10N/VL10P automatically triggers and outputs an alarm signal.

### High picture quality

The SNC-VL10N/VL10P incorporates Sony's 1/3 type CCD with Super HAD technology and DSP producing images of high picture quality and realizing high sensitivity. It achieves a maximum picture resolution of 720 x 486 (SNC-VL10N)/720 x 576 (SNC-VL10P) and a minimum illumination of 2.0 lx (F1.4).

### Simultaneous access for 100 users

A maximum of 100 people can simultaneously access the SNC-VL10N/VL10P and monitor images separately.

### Wide-angle view lens

The SNC-VL10N/VL10P incorporates a 2.3x Vari-focal lens (f=3.5 to 8.0 mm) that covers a wide viewing angle: 73.9° to 33.8° (H), 56.3° to 25.8° (V). The lens viewing angle, focus and iris are manually adjustable. The SNC-VL10N/VL10P can also be used with other CS-mount lenses (both manual and auto iris lenses).

### Easy GUI-based operation

Similar to an Internet home page, the view screen of the SNC-VL10N/VL10P is designed for easy and quick GUI-based operation. The 4.5 MB of flash memory embedded in the SNC-VL10N/VL10P allows users to customize the original GUI to suit their individual needs.

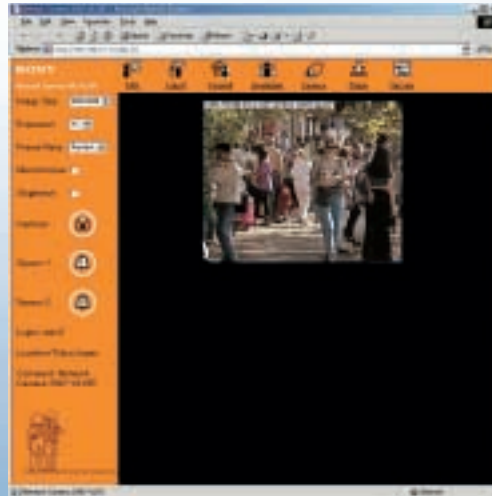

### Password protection

As well as allowing multi-user access, the SNC-VL10N/VL10P also maintains security by managing access to each camera site with password protection. There are five levels of password settings available. Each user will be assigned one of the following passwords: Administrator, Camera & Sensor, Sensor, Guest (view only).

### Analog video output

The SNC-VL10N can transmit analog video in NTSC format and the SNC-VL10P in PAL format for connecting to analog video equipment such as recorders, HSRs (Sony hard disk recorders), switchers, multiplexers and other peripheral equipment. Focal adjustment is easy because the camera can connect to an analog monitor.

### RS-232C/485 Transparency Interface

Control and operation of external equipment by an external control device such as a PC is possible via the SNC-VL10N/VL10P.



S Y S T E M   C O N F I G U R A T I O N

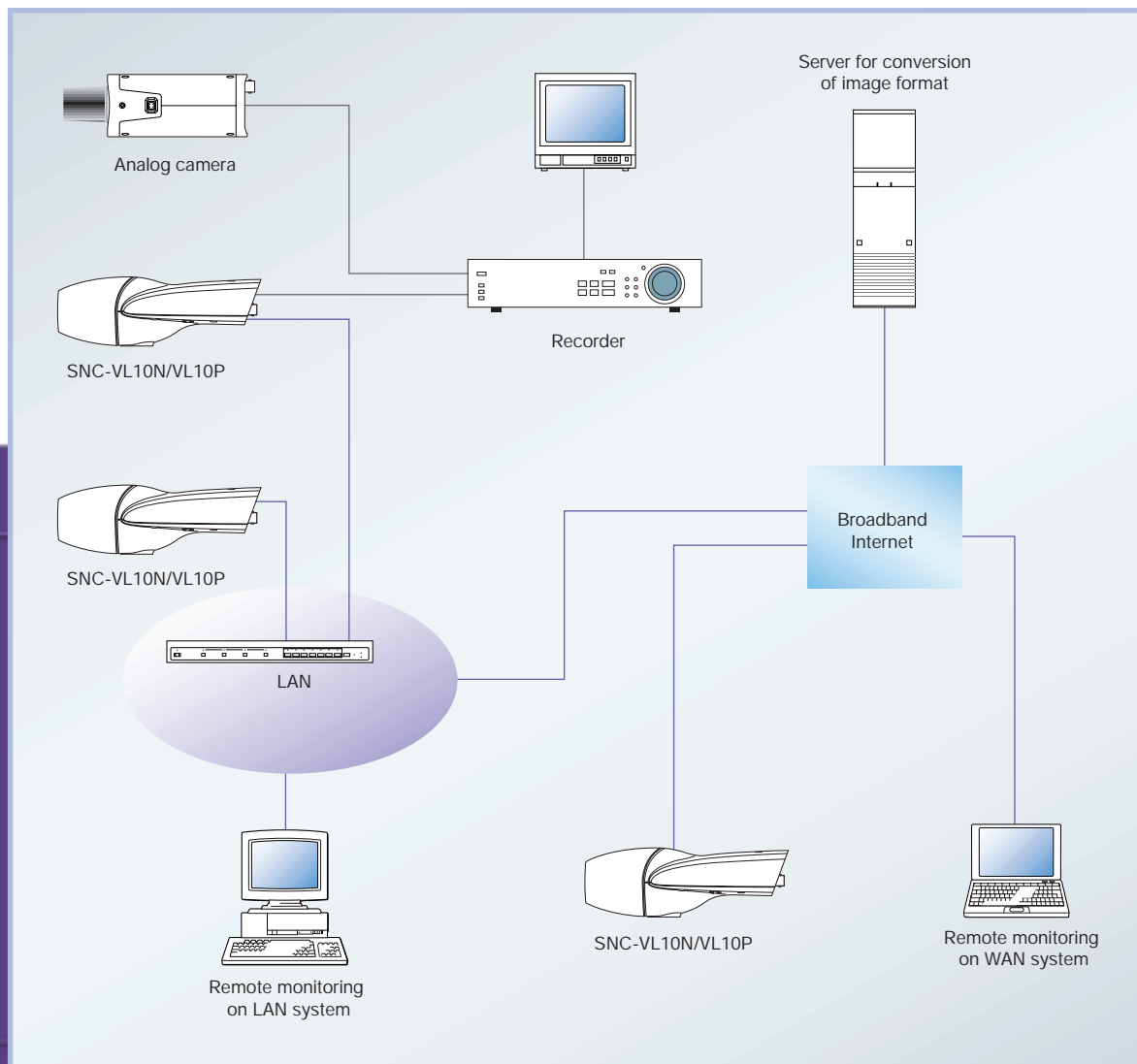

**SNC-VL10N/VL10P**

# SPECIFICATIONS

	SNC-VL10N	SNC-VL10P
<b>Hardware</b>		
CPU	32-bit RISC-Embedded processor	
Flash memory	8 MB (Default home page area: 4.5 MB)	
RAM	16 MB (Free area 6 MB)	
OS	Embedded Linux	
Image size	720 x 486 720 x 243 360 x 243 180 x 121 90 x 60	720 x 576 720 x 288 360 x 288 180 x 144 90 x 72
<b>Image compression</b>		
Algorithm	Wavelet	
Rate	10:1 to 200:1 (10 steps)	
<b>Performance</b>		
Frame rate	30 f/s (360 x 243)	25 f/s (360 x 288)
Local compression rate	Max 30 f/s	Max 25 f/s
<b>Security</b>		
	Password-based user authentication	
	IP-filtering (Secure Mode)	
	Image encryption	
<b>Camera</b>		
CCD	1/3 type Super HAD CCD™	
Effective picture elements	768 x 494	752 x 582
Sensing area	4.8 mm x 3.6 mm	
Horizontal resolution*	480 TV lines	
Signal system*	NTSC	PAL
Synchronization*	Internal	
Output signal*	Standard composite video signal 1 Vp-p, 75 Ω, sync negative	
Minimum illumination*	2.0 lx (F1.4)	
CCD iris	1/60 to 1/100,000	1/50 to 1/100,000
S/N ratio	More than 50 dB	
AGC	Always on	
White balance	ATW	

\* In case of analog output.

<b>Lens</b>	
Type	Vari-focal (focal length: 3.5 to 8.0 mm)
View angle	Wide 73.9° x 56.3° Tele 33.8° x 25.8°
Iris	Manual
Minimum object distance	0.5 m
Mount	CS

<b>General</b>	
Dimensions (W x H x D)	3 7/8 x 2 1/2 x 7 3/8 inches (96 x 63 x 186 mm)
Weight	12 oz (350 g)
Power requirement	DC 12 V via AC adaptor (100 to 240 V)
Power consumption	6.8 W (DC 12 V), 9.6 W (DC 48 V)
Operating temperature	14 °F to 122 °F (-10 °C to +50 °C)
Storage temperature	-40 °F to 140 °F (-40 °C to +60 °C)
Operating humidity	20% to 80%, Non-condensing
Storage humidity	20% to 95%, Non-condensing

<b>Connectors</b>	
	Video out
	DC 12 V
	10BASE-T Ethernet
	USB modem
	RS-232C/485 (Transparency only)
	Sensor I/O
	Volume for Video level
	Lens connector (DC servo)

<b>Supplied accessories</b>	
	AC adaptor, AC power cable, UTP category 5 cross cable, Wrench, CD-ROM (containing Set-up program & User's Guide), Installation manual

<b>Optional accessories</b>	
	TV 3310D-Canon Vari Focal DC servo Auto Iris lens

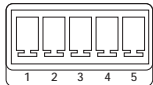
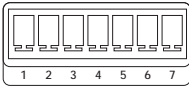
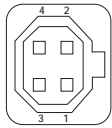
<b>PIN ASSIGNMENT</b>		
<b>1. RS-232C/485</b>		
	<b>Pin No.</b>	<b>Signal</b>
	1	RS232C-RXD
	2	RS232C-TXD
	3	GND
	4	RS485-A
	5	RS485-B
<b>2. SENSOR I/O</b>		
	<b>Pin No.</b>	
	1	Sensor + In+
	2	Sensor - In-
	3	Sensor1 + Out1+
	4	Sensor1 - Out1-
	5	Sensor2 + Out2+
	6	Sensor2 - Out2-
	7	GND GND
<b>3. Auto Iris Lens connector</b>		
	<b>Pin No.</b>	<b>DC servo</b>
	1	Control [-]
	2	Control [+]
	3	Drive [+]
	4	Drive [-] (GND)

## Rear Panel

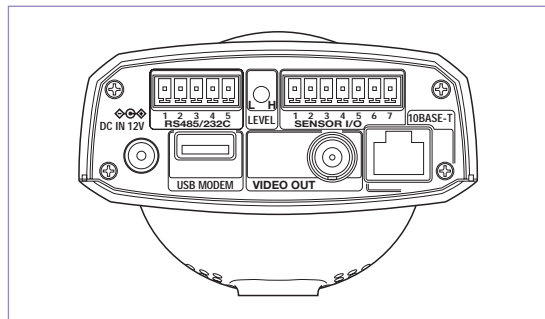

## Dimensions

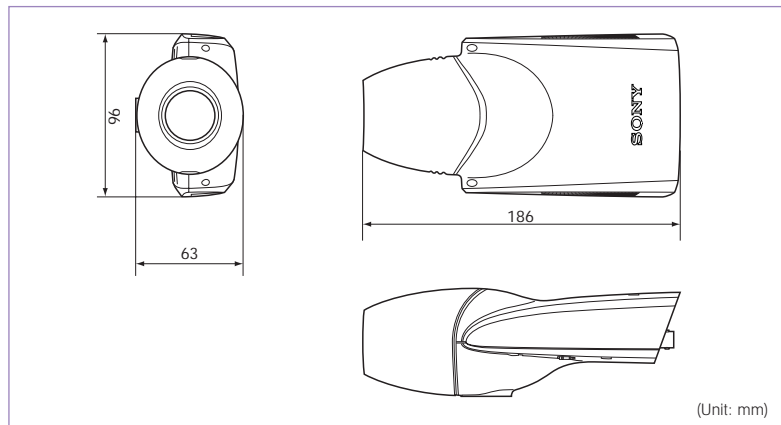

# SONY

Sony Electronics Inc.  
1 Sony Drive  
Park Ridge, NJ 07656  
www.sony.com/videocameras

IS-1152  
MK7822V1OHB02MAY

© 2002 Sony Electronics Inc. All rights reserved.  
Reproduction in whole or in part without written permission is prohibited.  
Features and specifications are subject to change without notice.  
All non-metric weights and measures are approximate.  
Sony and Super HAD CCD are trademarks of Sony.  
All other trademarks are the property of their respective owners.